

SYSTEM INTEGRITY CHECK



Your path to robust and reliable in-vehicle networking
Infineon's automotive networking solutions



Contents

Introduction	4
Product overview	7
Automotive transceivers	8
System Basis Chips (SBCs)	14
Infineon® Embedded Power ICs	22
AURIX™ microcontroller family	29
Support material	32
Automotive transceivers	32
System Basis Chips (SBCs)	32
Embedded Power	33
AURIX™ microcontroller family	34
Package information	35

Introduction

Automotive networking

Automotive networking technology is evolving fast, driven by a number of key trends. With a continuously increasing quantity of cars on the road and rising fuel costs, demand for energy efficiency is steadily growing. Worldwide legislation is establishing ever-stricter caps on CO₂ emissions. The spotlight is also on functional safety. With the ISO 26262 automotive standard increasingly moving into applications that were not typically safety-relevant, the bar is moving upwards and we are seeing increasingly granular system safety concepts. At the same time, complexity is on the incline. Growing consumer expectations are pushing for new and innovative comfort and safety features also in low-end segments, and this, in turn, is putting pressure on semiconductor manufacturers to reduce complexity through hardware/software compatibility and design-in support.

Last but not least, standardized, high-performance communication interfaces and protocols are needed to support the growing volume of data shared across automotive networks. CAN and LIN are the most commonly used in-vehicle networking interfaces. High-speed infotainment tends, however, to rely on Ethernet, MOST and LVDS, but these involve high implementation costs. CAN Partial Networking and CAN Flexible Data-rate (e.g. CAN FD) can help to balance the cost performance ratio here.

World leader in automotive electronics for over 40 years, we actively engage with many industry, standardization and research organizations to drive in-vehicle networking innovations capable of meeting today's demands for energy efficiency, safety, smooth interfacing and complexity management. Our broad portfolio extends from stand-alone transceivers through system basis chips to Embedded Power solutions for CAN, LIN and FlexRay protocols. We also offer microcontrollers with enhanced communication capabilities to support multiple protocols. All of our products are designed to deliver the exceptional high levels of ESD robustness and EMC performance required for harsh automotive environment. And to ease and accelerate your design-in process, we offer a range of demo boards, configuration tools, tool chains and development platforms.

Automotive standards

Infineon is actively participating as a member in several standardization groups and is also funding some research projects with major OEM's in terms of networking:



Local Interconnect Network (LIN) is used to interconnect sensors, actuators and control modules where the high bandwidth and fast reaction time is not required. LIN is mainly used for comfort functions.



Controller Area Network (CAN) also called classical CAN is the most used communication network in automotive applications and allows communication speeds up to 1 Mbit/s.



CAN Flexible Data-Rate (CAN FD) is the successor of the classical CAN for faster communication with communication speeds up to 5 Mbit/s and increased payload providing up to 64 data bytes per frame.



CAN Partial Networking (CAN PN) also known as CAN with selective wake feature has been introduced to reduce the current consumption on vehicle level by enabling to switch off or on dedicated electronic control units (ECUs).



FlexRay provides up to 10 Mbit/s communication speed per channel for advanced in-vehicle networks. It provides fault-tolerant communication for safety related applications.



Ethernet is the newest automotive network providing not only improved bandwidth for e.g. 360° surround view monitoring, but also lower latencies for control applications.

Your partner of trust for automotive network solutions

Infineon automotive networking products

- > Comprehensive product portfolio of standalone transceivers, system basis chips and Embedded Power solutions
- > Microcontrollers with enhanced communication capabilities to support flexible communication protocols



As World leader in automotive electronics for over 40 years, Infineon focuses on the in-vehicle networking, a major driver today for innovation in the automotive field, meeting the ever-increasing demand of consumers for energy efficiency, mobility and security.

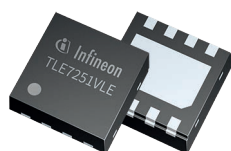

With over fifteen years' experience developing communication interfaces, Infineon offers a broad product portfolio of standalone transceivers, System Basis Chips (SBCs) and Embedded Power solutions for CAN, LIN and FlexRay networks. AURIX™ microcontrollers with enhanced communication capabilities to support flexible communication protocols such as LIN, SPI, I²C, CAN, CAN FD, FlexRay, Ethernet, DigRF/LVDS complement the offering.



Continuously improving its SPT chip technology, Infineon provides solutions for the challenges faced by the automotive industry, featuring outstanding ESD robustness and best in class EMC performance in order to fulfill even the future OEM requirements.



In this brochure Infineon has put together its standalone transceiver, system basis chip, Embedded Power and AURIX™ microcontroller portfolio, with a detailed description of their distinctive key features and benefits.



For more detailed information please visit the Infineon website at www.infineon.com/automotive-networking or contact your sales or distribution partners www.infineon.com/WhereToBuy.



Product overview

	LIN	CAN FD	CANFD + LIN	FlexRay
Standalone transceivers	TLE7257SJ/LE TLE7258SJ/LE TLE7259-3GE/-3LE TLE7269G	TLE7250SJ/LE TLE7250VSJ/VLE TLE7250XSJ/XLE TLE7251VSJ/VLE TLE9250SJ/LE TLE9250VSJ/VLE TLE9250XSJ/XLE TLE9251VSJ/VLE TLE9252VSK/WLC ¹⁾ TLE9255WSK/WLC		TLE9221SX TLE9222PX TLE9222LC ¹⁾
Transceiver + LDO	TLE8458x TLE8457x			
System Basis Chips		TLE926x TLE927x	TLE926x TLE927x	
Embedded Power	TLE984x TLE986x TLE987X			

1) In development



Automotive transceivers

Due to the ever-increasing demand for data exchange in modern vehicles, the automotive industry implemented networks such as CAN (Controller Area Network), LIN (Local Interconnect Network) and FlexRay protocol-based bus systems.

Infinion offers a broad product portfolio of automotive transceivers – all of which are perfectly suited and designed to withstand the harsh automotive environment – for the various automotive bus segments.

Different transceiver types are used in accordance with the respective vehicle network architecture and the related ECU supply path. Infineon transceivers ensure reliable communication and help minimize the current consumption and associated CO₂ emissions at the vehicle level. Thanks to their high performance, ruggedness and reliable communication, Infineon’s transceiver products offer the ultimate in value.

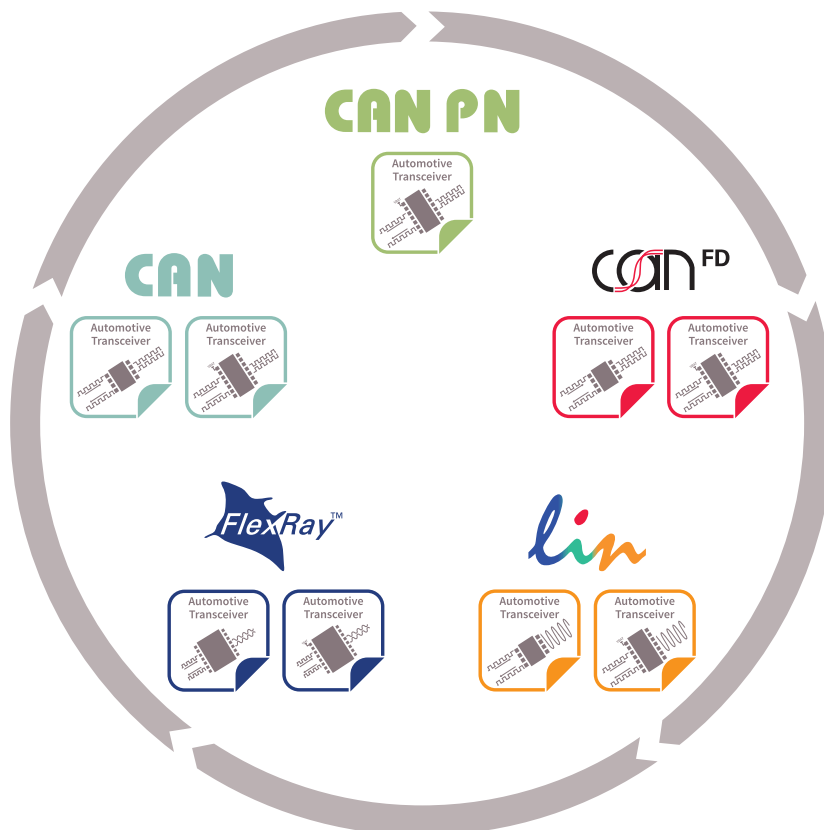



Infineon offers a complete LIN transceiver and new LIN LDO family in standard DSO-8 as well as tiny TSON-8 packages

Selection tree – Automotive LIN transceivers

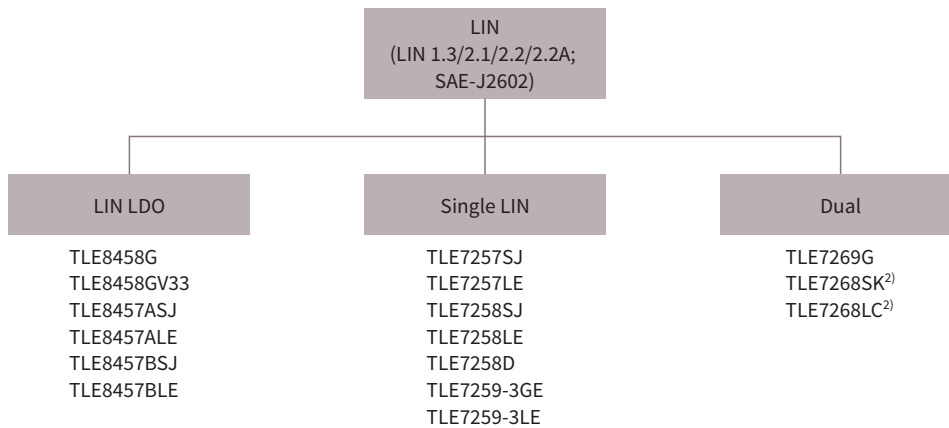

Product overview								
Product name	Transmission rate (max)	Low-power mode I_q [μ A] (max)	Bus wake-up capability	Wake-up inputs	Number of channels	Bus failure management	Fast programming	Package ¹⁾
LIN LDO								
TLE8458G	20 kbit/s	< 12 sleep mode	●	●	1	●	●	DSO-8
TLE8458GV33	20 kbit/s	< 12 sleep mode	●	●	1	●	●	DSO-8
TLE8457ASJ	20 kbit/s	< 16 sleep mode	●		1	●		DSO-8
TLE8457ALE	20 kbit/s	< 16 sleep mode	●		1	●		TSON-8
TLE8457BSJ	20 kbit/s	< 16 sleep mode	●		1	●		DSO-8
TLE8457BLE	20 kbit/s	< 16 sleep mode	●		1	●		TSON-8
Single LIN								
TLE6258-2G	20 kbit/s	< 40 sleep mode	●		1			DSO-8
TLE7257SJ	20 kbit/s	< 15 sleep mode	●		1	●		DSO-8
TLE7257LE	20 kbit/s	< 15 sleep mode	●		1	●		TSON-8
TLE7258SJ	20 kbit/s	< 15 sleep mode	●		1	●		DSO-8
TLE7258LE	20 kbit/s	< 15 sleep mode	●		1	●		TSON-8
TLE7258D	20 kbit/s	< 15 sleep mode	●		1	●		TSON-8
TLE7259-3GE	20 kbit/s	< 10 sleep mode	●	●	1	●		DSO-8
TLE7259-3LE	20 kbit/s	< 10 sleep mode	●	●	1	●		TSON-8
Dual LIN								
TLE7269G	20 kbit/s	< 10 sleep mode	●	●	2	●	●	DSO-14
TLE7268LC ²⁾	20 kbit/s	< 20 sleep mode	●		2	●		TSON-14
TLE7268SK ²⁾	20 kbit/s	< 20 sleep mode	●		2	●		DSO-14

1) See packages on page 36

2) Coming Q2/2017



Automotive transceivers

CAN



Classical CAN transceivers are available in standard DSO-8 and DSO-14 packages, along with tiny leadless TSON-8 packages.

CAN^{FD}



CAN transceivers for flexible data-rate are making CAN faster and do support data-rates up to 5 Mbps/s.

CAN PN



CAN transceivers for partial networking are improving energy efficiency and making cars greener.

Block diagram example of high-speed CAN: TLE7250V

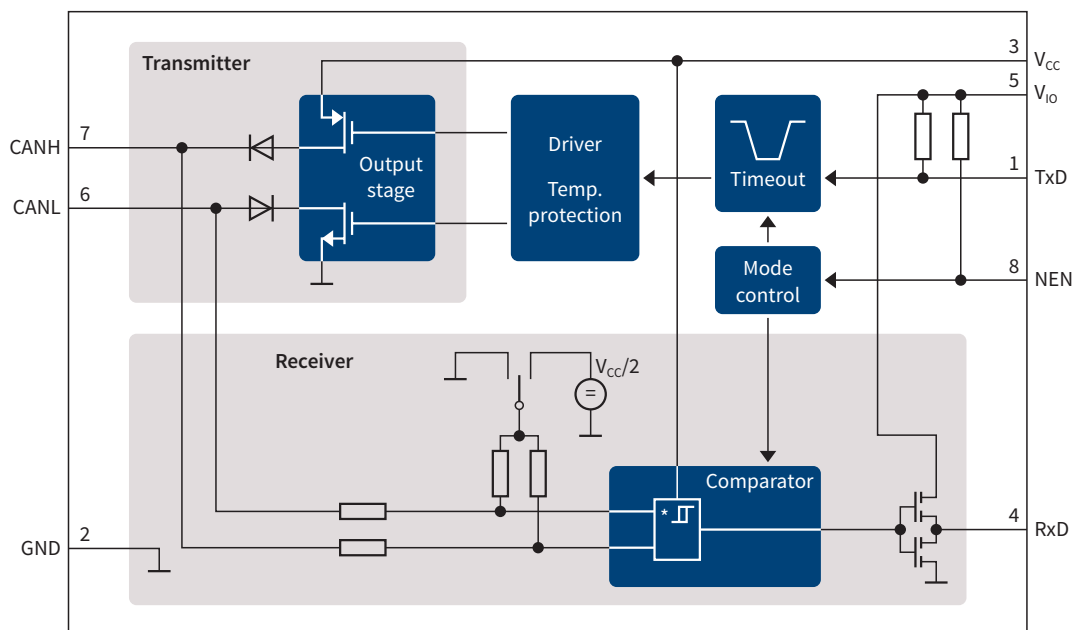

Selection tree – Automotive CAN and CAN FD transceivers

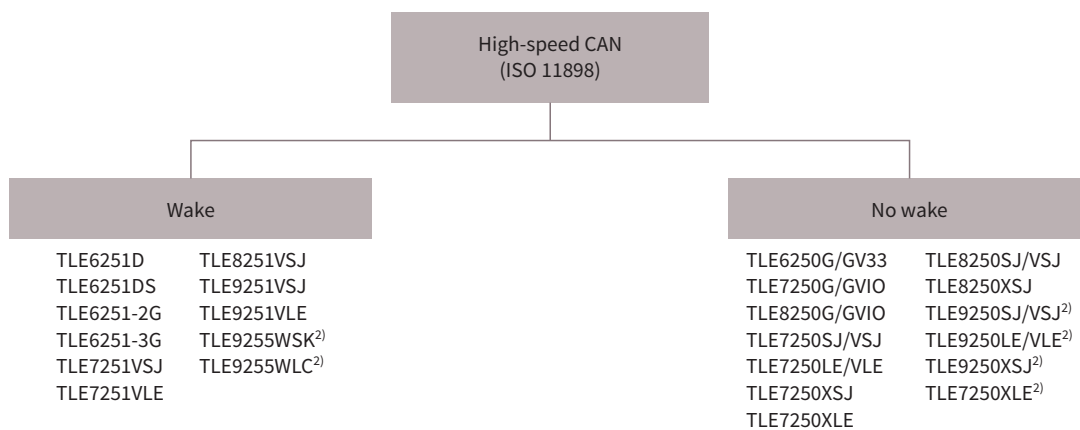

Product overview







Product name	Transmission rate (max)	Low-power mode I _q [μA] (max)	Bus wake-up capability	Wake-up inputs	Number of channels	Bus failure management	CAN FD	Package ¹⁾
High-speed CAN ISO 11898-2								
TLE6250G	1 Mbit/s	< 10 @ 5 V stand-by			1			DSO-8
TLE6250GV33	1 Mbit/s	< 10 @ 5 V stand-by			1			DSO-8
TLE7250G	1 Mbit/s	< 15 @ 5 V stand-by			1			DSO-8
TLE7250GVIO	1 Mbit/s	< 15 @ 5 V stand-by			1			DSO-8
TLE8250G	1 Mbit/s	< 15 @ 5 V stand-by			1			DSO-8
TLE8250GVIO	1 Mbit/s	< 15 @ 5 V stand-by			1			DSO-8
NEW! TLE7250SJ TLE8250SJ	2 Mbit/s	< 12 @ 5 V power save mode			1		●	DSO-8
NEW! TLE7250LE	2 Mbit/s	< 12 @ 5 V power save mode			1		●	TSON-8
NEW! TLE7250VSJ TLE8250VSJ	2 Mbit/s	< 8 @ 5 V power save mode			1		●	DSO-8
NEW! TLE7250VLE	2 Mbit/s	< 8 @ 5 V power save mode			1		●	TSON-8
NEW! TLE7250XSJ TLE8250XSJ	2 Mbit/s	n/a			1		●	DSO-8
NEW! TLE7250XLE	2 Mbit/s	n/a			1		●	TSON-8
NEW! TLE9250SJ ²⁾	5 Mbit/s	< 20 @ 5 V power save mode			1		●	DSO-8
NEW! TLE9250LE ²⁾	5 Mbit/s	< 20 @ 5 V power save mode			1		●	TSON-8
NEW! TLE9250VSJ ²⁾	5 Mbit/s	< 15 @ 5 V power save mode			1		●	DSO-8
NEW! TLE9250VLE ²⁾	5 Mbit/s	< 15 @ 5 V power save mode			1		●	TSON-8
NEW! TLE9250XSJ ²⁾	5 Mbit/s	n/a			1		●	DSO-8
NEW! TLE9250XLE ²⁾	5 Mbit/s	n/a			1		●	TSON-8

1) See packages on page 36

2) Coming Q1/2017

Automotive transceivers

Product overview

Product name	Transmission rate (max)	Low-power mode I_q [μ A] (max)	Bus wake-up capability	Wake-up inputs	Number of channels	Bus failure management	CAN FD	Package ¹⁾
High-speed CAN ISO 11898-5								
TLE6251D	1 Mbit/s	< 25 @ 5 V stand-by	●		1			DSO-8
TLE6251DS	1 Mbit/s	< 30 @ 5 V stand-by	●		1			DSO-8
TLE6251-2G	1 Mbit/s	< 30 sleep mode	●	●	1	●		DSO-14
TLE6251-3G	1 Mbit/s	< 30 sleep mode	●	●	1	●		DSO-14
NEW! TLE7251VSJ TLE8251VSJ 	2 Mbit/s	< 14 μ A @ 5 V stand-by	●		1		●	DSO-8
NEW! TLE7251VLE 	2 Mbit/s	< 14 μ A @ 5 V stand-by	●		1		●	TSON-8
NEW! TLE9251VSJ ²⁾ 	5 Mbit/s	< 15 μ A @ 5 V stand-by	●		1		●	DSO-8
NEW! TLE9251VLE ²⁾ 	5 Mbit/s	< 15 μ A @ 5 V stand-by	●		1		●	TSON-8
NEW! TLE9255WSK ²⁾ 	5 Mbit/s	< 26 sleep mode	●	●	1		●	DSO-14
NEW! TLE9255WLC ²⁾ 	5 Mbit/s	< 26 sleep mode	●	●	1		●	TSON-14
Fault-tolerant CAN ISO 11898-3								
TLE6254-3G	125 kbit/s	< 65 sleep mode	●	●	1	●		DSO-14

1) See packages on page 36

2) Coming Q1/2017



Infineon provides FlexRay transceivers in SSOP-16 and TSSOP-14 for reliable communication in safety-related applications.

Product overview

Product name	Transmission rate (max)	I_q [μ A]	Bus wake-up capability	Wake-up inputs	Number of channels	Bus failure management	Package ¹⁾
FLexRay							
TLE9221SX	10 Mbit/s	< 45 sleep mode	●	●	1	●	SSOP-16
NEW! TLE9222PX	10 Mbit/s	< 45 stand-by mode	●		1	●	TSSOP-14
NEW! TLE9222LC ²⁾	10 Mbit/s	< 45 stand-by mode	●		1	●	TSON-14

1) See packages on page 36

2) Coming Q1/2017



OEM



RoHS

www.infineon.com/automotive-transceivers



System Basis Chips (SBCs)

Mid-Range System Basis Chip family supporting CAN Flexible Data-rate (FD) and Partial Networking (PN)

Infineon's highly integrated Mid-Range System Basis Chip (SBC) family TLE926x offers best performance and scalability for various automotive applications. The Mid-Range SBCs feature up to three low-drop voltage regulators with 5 V or 3.3 V output voltage options for microcontroller, network transceivers, sensors and other peripherals' power supply. As communication interfaces they incorporate one HS CAN transceiver (including Partial Networking option and Flexible Data-rate performance) and up to two LIN transceivers complying with the latest automotive standards and OEM requirements. The devices include diagnostic and supervision features for support of ECU functional safety concepts like under-voltage monitoring, window watchdog

with reset, fail-safe operating mode, and fail-safe outputs. Four high-side switches are available in order to drive external loads, three wake-inputs and two General Purpose Input-Outputs (GPIOs) allow monitoring of inputs or activation of loads. The Mid-Range SBCs can be put into low power modes with full wake capability for very low quiescent current consumption in order to support applications that are connected permanently to the battery. All devices feature an exposed pad VQFN-48 (7 mm x 7 mm) power package supporting Automatic Optical Inspection (AOI). The entire family is pin-to-pin and software compatible, also to other Infineon SBC families, and is designed to withstand the severe conditions of automotive applications.

Key features

- › Integrated low-drop voltage regulator (5 V or 3.3 V up to 250 mA)
- › Integrated low-drop voltage regulator (5 V up to 100 mA), protected for off-board usage
- › Voltage regulator (5 V, 3.3 V or 1.8 V) with external PNP transistor, protected for off-board usage or for load-sharing
- › 1 high-speed CAN transceiver supporting FD communication up to 2 Mbit/s featuring CAN Partial Networking FD tolerant mode¹⁾
- › 2 LIN transceivers LIN2.2/J2602
- › 4 high-side outputs 7 Ω typ.
- › 2 HV GPIOs, 3 HV wake inputs
- › Interrupt, reset output
- › Integrated fail-safe functions: 3 fail-safe outputs, watchdog, fail-safe operating modes
- › 16-bit SPI for configuration and diagnostics
- › Voltage, current and temperature protection and monitoring

1) The CAN FD requirements for transceiver are not finalized. All statements regarding CAN FD are therefore based on Infineon's today's knowledge and expectation on the future CAN FD standard currently being worked out.

Key benefits

- › Reduced system cost through low component count and small PCB footprint
- › Low-drop voltage regulators for on- and off-board supply
- › Wide supply input voltage and temperature range
- › High-performance network transceivers
- › Flexible number of integrated LIN transceivers
- › Very low quiescent current modes
- › Very small package supporting AOI
- › Pin and software compatibility amongst all family members
- › Excellent EMC and ESD performance meeting major car OEM requirements

Target applications

- › Body Control Modules (BCM) and Gateways
- › Heating, ventilation and air conditioning (HVAC)
- › Door, roof, tailgate, trailer and closure modules
- › Passive keyless entry, passive start modules
- › Seat control modules
- › Light control modules
- › Gear shifters and selectors



TLE9263 application diagram

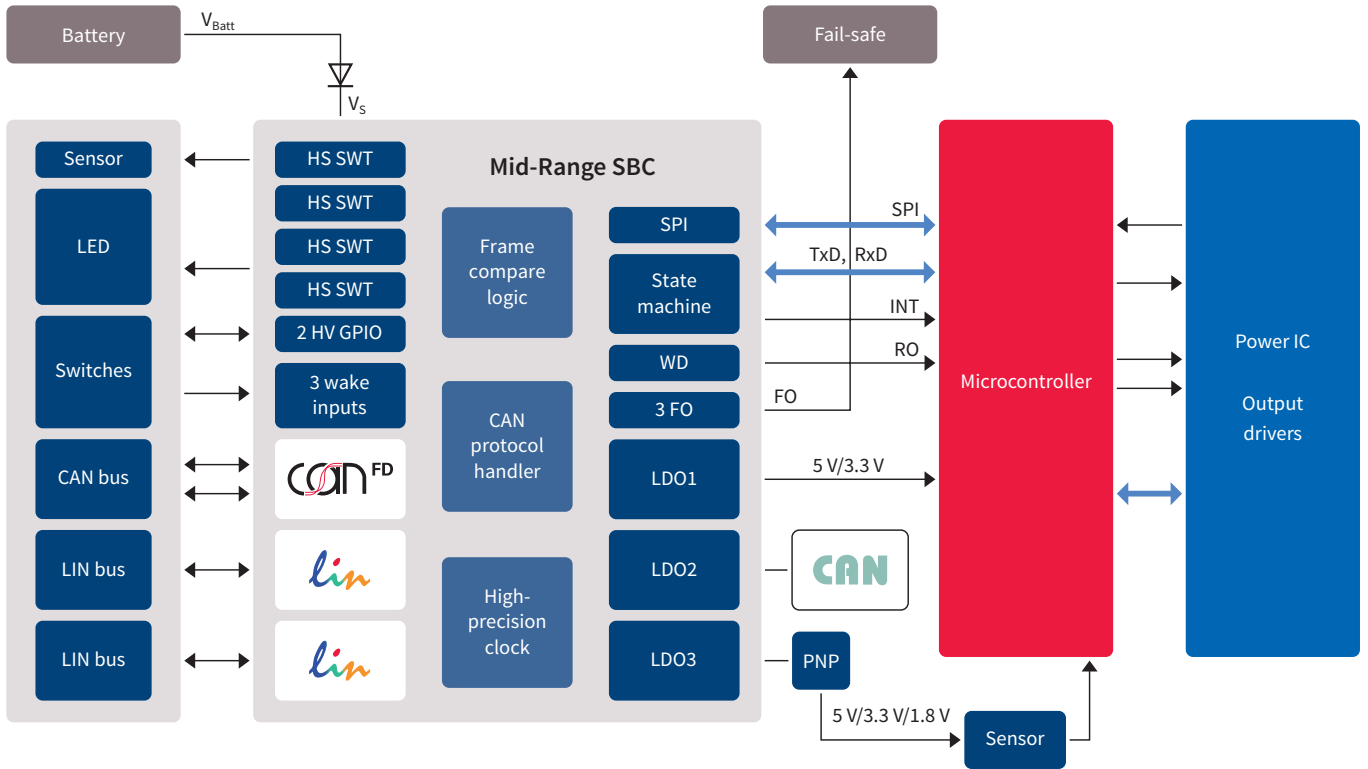

Mid-Range SBC family overview

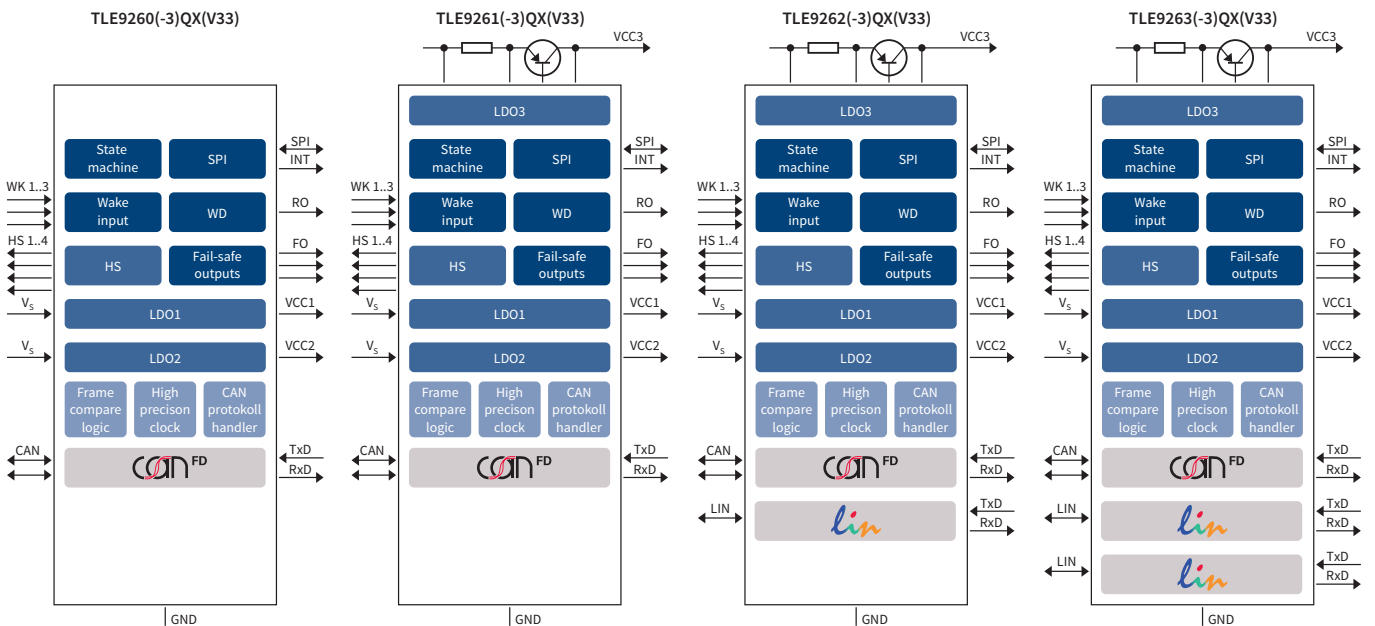

System Basis Chips (SBCs)

DC-DC System Basis Chip family supporting CAN Flexible Data-rate (FD)

Infineon's highly integrated DC-DC System Basis Chip (SBC) family TLE927xQX offers optimal performance and scalability for various automotive applications. DC-DC SBC features a switch mode power supply voltage regulator (SMPS) with 5 V or 3.3 V output voltage, one 5 V low-drop voltage regulator, one HS CAN and up to four LIN transceivers complying with the latest automotive standards and OEM requirements. The devices include fail-safe features for supporting ECU functional safety concepts, high-voltage

wake-input for monitoring inputs, along with a very low quiescent current in low-power modes with full wake-up capability. All devices feature an exposed pad VQFN-48 (7 mm x 7 mm) power package (supporting AOI). The entire family is not only pin-to-pin and software compatible, but also compatible with other Infineon SBC families, and is designed to withstand the severe conditions of automotive applications.

Key features

- › Integrated high-efficiency SMPS buck converter with edge shaping for an optimized EMC performance (5 V or 3.3 V up to 750 mA)
- › The SMPS boost controller with edge shaping for an optimized EMC performance enables functionality at a low supply voltage ($V_{SUP} > 3 V$) with external power switching
- › Integrated low-drop voltage regulator (5 V up to 100 mA) protected for off-board usage
- › 1 high-speed CAN transceiver ISO 11898-2/-5 supporting CAN Flexible Data-rate (CAN FD) up to 2 Mbps¹⁾ and suitable for chokeless operation at up to 500 kbps
- › Up to 4 LIN transceivers LIN2.2/J2602
- › Fully compliant with "Hardware Requirements for LIN, CAN and FlexRay Interfaces in Automotive Applications" Revision 1.3, 2012-05-04
- › 1 HV wake input for switch status monitoring
- › Interrupt, reset output
- › Integrated fail-safe functions:
3 fail-safe outputs, 1 fail-safe input, watchdog, fail-safe operating modes
- › 16-bit SPI for configuration and diagnostics (compatible with all new-generation SBC TLE926x and TLE927x)
- › Voltage, current and temperature protection and monitoring

1) The CAN FD requirements for transceivers are not finalized. All statements regarding CAN FD are therefore based on Infineon's current knowledge and expectations of the future CAN FD standard currently being compiled.

Key benefits

- › High-efficiency SMPS buck and boost for supplying high current even at low battery voltage
- › Low-drop voltage regulator for on- and off-board supply
- › CAN FD transceiver suitable for chokeless operation
- › Flexible number of integrated LIN transceivers
- › Very low quiescent current
- › Very small leadless package supporting AOI
- › Pin compatibility among all family members
- › Wide supply input voltage and temperature range
- › Reduced system cost thanks to a low component count and less PCB space
- › Excellent EMC and ESD performance meeting major automotive OEM requirements

Target applications

- › Body control modules
- › Gateway
- › Climate control

TLE9273 application diagram

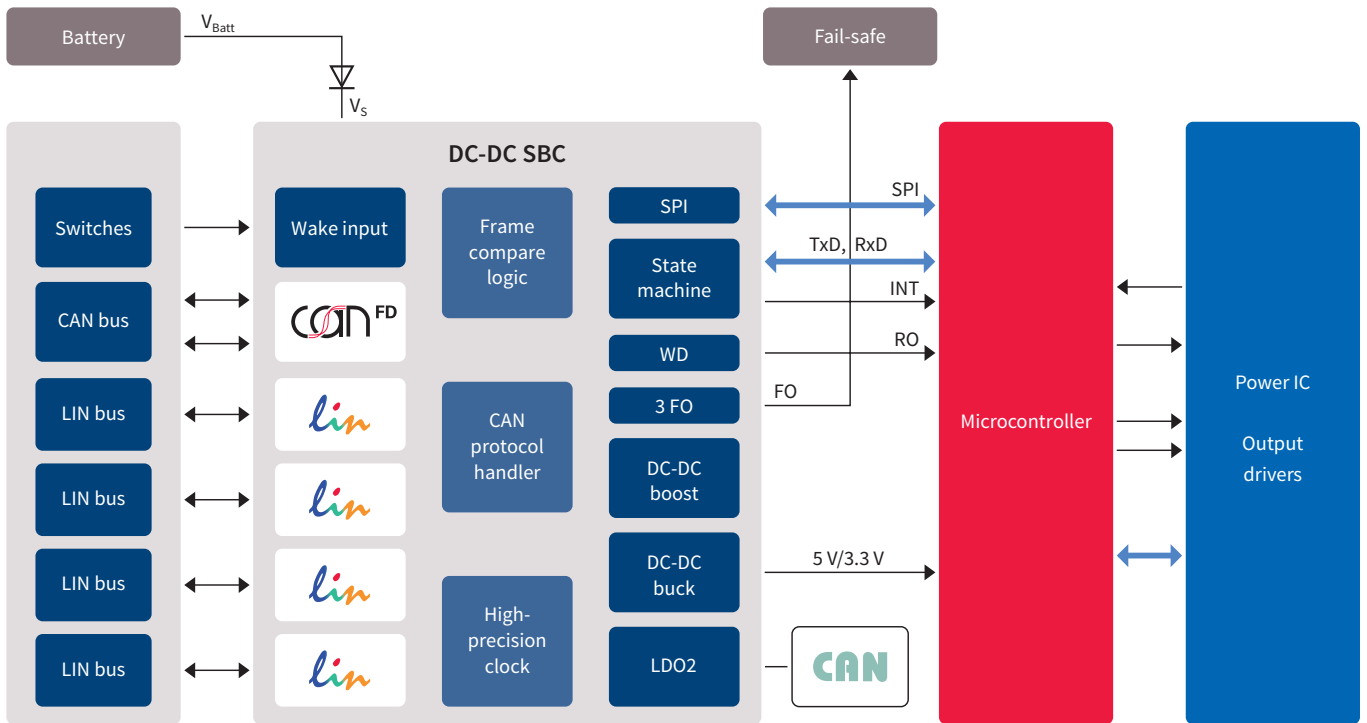

DC-DC System Basis Chip family overview

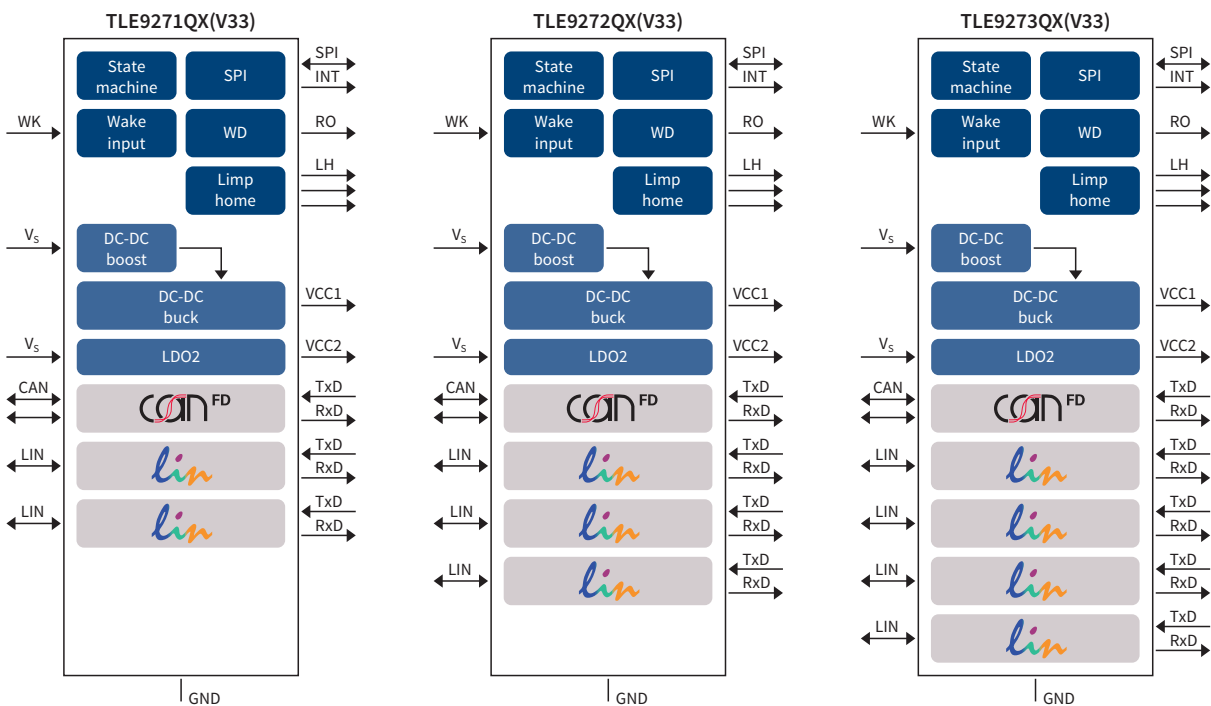

System Basis Chips (SBCs)

Multi-CAN Power System Basis Chip family supporting CAN Flexible Data-rate (FD) and Partial Networking (PN)

Infinion’s Multi-CAN Power System Basis Chip (SBC) TLE9278 family offers the highest level of integration at smallest footprint for automotive applications requiring multiple channels of CAN transceivers like gateways and high-end Body Control Modules (BCM).

A high-efficient Switch Mode Power supply (SMPS) buck regulator provides an external 5 V or 3.3 V output voltage at up to 750 mA while an additional DC-DC boost converter supports applications or conditions at low supply input voltages.

Key features

- > 4x CAN Flexible Data-rate transceivers up to 5 Mbit/s
- > Partial Networking w/ “-3” variants
- > Buck regulator up to 750 mA
- > Boost controller at 6.5/8/10/12 V
- > 16-bit serial peripheral interface
- > Time-out/window watchdog
- > Failsafe-output
- > Low power modes
- > 7 x 7 mm VQFN package

Key benefits

- > Highly integrated solution for multi-Channel CAN applications
- > Highly efficient power supply
- > High power for strong processors
- > Tolerant to low voltage line drops
- > Easy configuration and control
- > Advanced diagnostics functions
- > Failsafe functions for safety
- > Power saving modes
- > Minimal PCB footprint

TLE9278 application diagram

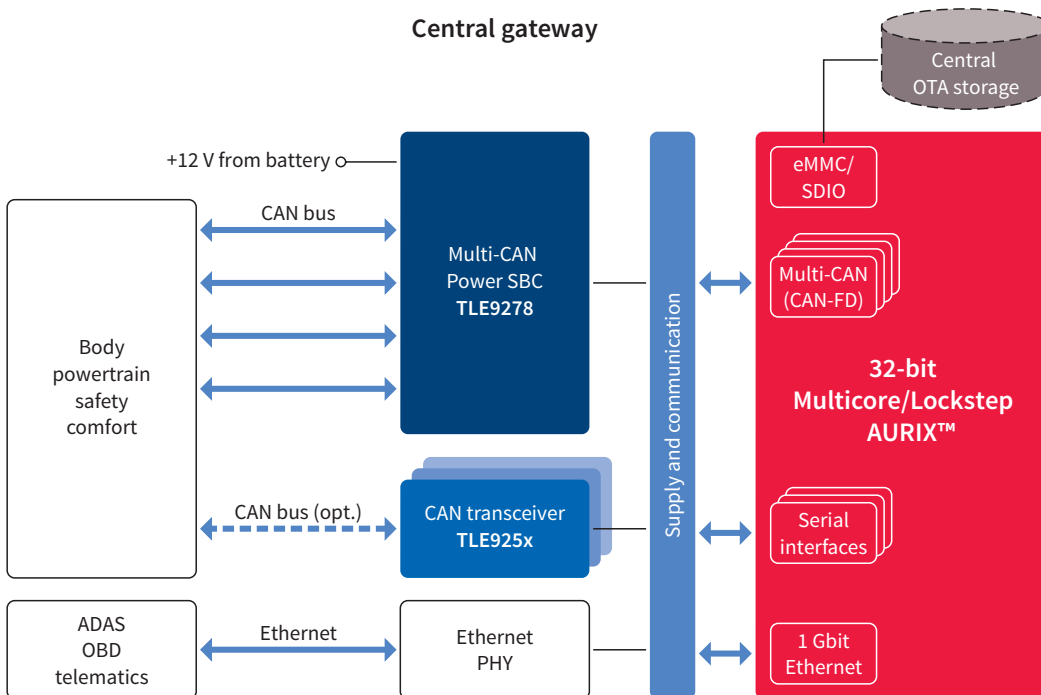

RoHS



www.infineon.com/sbc

Body System ICs – System Basis Chips product overview

Product name	Family name	Transmission rate	I_r [μ A]	I_o [μ A]	V_{reg1} [V]	V_{reg2} [V]	V_{reg3} [V]	CAN	LIN	Wake-up inputs	Watchdog	Output drivers	Package ¹⁾
High-Speed CAN ISO 11898-2 /-5 / LIN 2.2A													
TLE9260QX(V33)	Mid-range SBC	2 Mbit/s (CAN) 20 kbit/s 10.4 kbit/s (LIN)	30 (typ) sleep mode (V_{reg1} off)	50 (typ) stop mode (V_{reg1} on)	250 mA @ 5 V (3.3 V on V33 variant)	100 mA @ 5 V	-	1x High-speed CAN ²⁾ ISO 11898-5	-	3 high-voltage (cyclic sense)	Yes (window watchdog)	4x high-side switch 150 mA, 3 fail-safe outputs	VQFN-48
TLE9261QX(V33)	Mid-range SBC	2 Mbit/s (CAN) 20 kbit/s 10.4 kbit/s (LIN)	30 (typ) sleep mode (V_{reg1} off)	50 (typ) stop mode (V_{reg1} on)	250 mA @ 5 V (3.3 V on V33 variant)	100 mA @ 5 V	400 mA @ 5 V/3.3 V (3.3 V/1.8 V avail. on V33 variant)	1x High-speed CAN ²⁾ ISO 11898-5	-	3 high-voltage (cyclic sense)	Yes (window watchdog)	4x high-side switch 150 mA, 3 fail-safe outputs	VQFN-48
TLE9262QX(V33)	Mid-range SBC	2 Mbit/s (CAN) 20 kbit/s 10.4 kbit/s (LIN)	30 (typ) sleep mode (V_{reg1} off)	50 (typ) stop mode (V_{reg1} on)	250 mA @ 5 V (3.3 V on V33 variant)	100 mA @ 5 V	400 mA @ 5 V/3.3 V (3.3 V/1.8 V avail. on V33 variant)	1x High-speed CAN ²⁾ ISO 11898-5	1x LIN 2.x and SAE J2602	3 high-voltage (cyclic sense)	Yes (window watchdog)	4x high-side switch 150 mA, 3 fail-safe outputs	VQFN-48
TLE9263QX(V33)	Mid-range SBC	2 Mbit/s (CAN) 20 kbit/s 10.4 kbit/s (LIN)	30 (typ) sleep mode (V_{reg1} off)	50 (typ) stop mode (V_{reg1} on)	250 mA @ 5 V (3.3 V on V33 variant)	100 mA @ 5 V	400 mA @ 5 V/3.3 V (3.3 V/1.8 V avail. on V33 variant)	1x High-speed CAN ²⁾ ISO 11898-5	2x LIN 2.x and SAE J2602	3 high-voltage (cyclic sense)	Yes (window watchdog)	4x high-side switch 150 mA, 3 fail-safe outputs	VQFN-48
TLE9271QX(V33) ⁴⁾	DC-DC SBC	2 Mbit/s (CAN) 20 kbit/s 10.4 kbit/s (LIN)	30 (typ) sleep mode (V_{reg2} off)	55 (typ) stop mode (V_{reg2} off)	750 mA @ 5 V (3.3 V on V33 variant)	100 mA @ 5 V	-	1x High-speed CAN ²⁾ ISO 11898-5	2x LIN 2.x and SAE J2602	1 high-voltage	Yes (window watchdog)	3 fail-safe outputs	VQFN-48
TLE9272QX(V33) ⁴⁾	DC-DC SBC	2 Mbit/s (CAN) 20 kbit/s 10.4 kbit/s (LIN)	30 (typ) sleep mode (V_{reg2} off)	55 (typ) stop mode (V_{reg2} off)	750 mA @ 5 V (3.3 V on V33 variant)	100 mA @ 5 V	-	1x High-speed CAN ²⁾ ISO 11898-5	3x LIN 2.x and SAE J2602	1 high-voltage	Yes (window watchdog)	3 fail-safe outputs	VQFN-48
TLE9273QX(V33) ⁴⁾	DC-DC SBC	2 Mbit/s (CAN) 20 kbit/s 10.4 kbit/s (LIN)	30 (typ) sleep mode (V_{reg2} off)	55 (typ) stop mode (V_{reg2} off)	750 mA @ 5 V (3.3 V on V33 variant)	100 mA @ 5 V	-	1x High-speed CAN ²⁾ ISO 11898-5	4x LIN 2.x and SAE J2602	1 high-voltage	Yes (window watchdog)	3 fail-safe outputs	VQFN-48
TLE9278QX	Multi-CAN Power SBC	5 Mbit/s	30	55	750 mA @ 5 V		400 mA @ 5 V/3.3 V/1.8 V/1.2 V	4x CAN FD		1 high-voltage	Yes (window watchdog)	1 fail-safe output	VQFN-48
TLE9278QX V33	Multi-CAN Power SBC	5 Mbit/s	30	55	750 mA @ 3.3 V		400 mA @ 5 V/3.3 V/1.8 V/1.2 V	4x CAN FD-		1 high-voltage	Yes (window watchdog)	1 fail-safe output	VQFN-48

1) See packages on page 36

2) CAN FD up to 2 Mbit/s

3) CAN PN FD tolerant

4) Coming Q2/2017

System Basis Chips (SBCs)

Body System ICs – System Basis Chips product overview (cont'd)

Product name	Family name	Transmission rate	I_{r} [μ A]	I_{o} [μ A]	$V_{reg,1}$ [V]	$V_{reg,2}$ [V]	$V_{reg,3}$ [V]	CAN	LIN	Wake-up inputs	Watchdog	Output drivers	Package ¹⁾
High-Speed CAN ISO 11898-2/-5/-6 / LIN 2.2A													
TLE9260-3QX(V33)	Mid-range SBC	2 Mbit/s (CAN) 20 kbit/s 10.4 kbit/s (LIN)	30 (typ) sleep mode ($V_{reg,1}$ off)	50 (typ) stop mode ($V_{reg,1}$ on)	250 mA @ 5 V (3.3 V on V33 variant)	100 mA @ 5 V	-	1x High-speed CAN ^{2) 3)} ISO 11898-6	-	3 high-voltage (cyclic sense)	Yes (window watchdog)	4x high-side switch 150 mA, 3 fail-safe outputs	VQFN-48
TLE9261-3QX(V33)	Mid-range SBC	2 Mbit/s (CAN) 20 kbit/s 10.4 kbit/s (LIN)	30 (typ) sleep mode ($V_{reg,1}$ off)	50 (typ) stop mode ($V_{reg,1}$ on)	250 mA @ 5 V (3.3 V on V33 variant)	100 mA @ 5 V	400 mA @ 5 V/3.3 V (3.3 V/1.8 V avail. on V33 variant)	1x High-speed CAN ^{2) 3)} ISO 11898-6	-	3 high-voltage (cyclic sense)	Yes (window watchdog)	4x high-side switch 150 mA, 3 fail-safe outputs	VQFN-48
TLE9262-3QX(V33)	Mid-range SBC	2 Mbit/s (CAN) 20 kbit/s 10.4 kbit/s (LIN)	30 (typ) sleep mode ($V_{reg,1}$ off)	50 (typ) stop mode ($V_{reg,1}$ on)	250 mA @ 5 V (3.3 V on V33 variant)	100 mA @ 5 V	400 mA @ 5 V/3.3 V (3.3 V/1.8 V avail. on V33 variant)	1x High-speed CAN ^{2) 3)} ISO 11898-6	1x LIN 2.x and SAE J2602	3 high-voltage (cyclic sense)	Yes (window watchdog)	4x high-side switch 150 mA, 3 fail-safe outputs	VQFN-48
TLE9263-3QX(V33)	Mid-range SBC	2 Mbit/s (CAN) 20 kbit/s 10.4 kbit/s (LIN)	30 (typ) sleep mode ($V_{reg,1}$ off)	50 (typ) stop mode ($V_{reg,1}$ on)	250 mA @ 5 V (3.3 V on V33 variant)	100 mA @ 5 V	400 mA @ 5 V/3.3 V (3.3 V/1.8 V avail. on V33 variant)	1x High-speed CAN ^{2) 3)} ISO 11898-6	2x LIN 2.x and SAE J2602	3 high-voltage (cyclic sense)	Yes (window watchdog)	4x high-side switch 150 mA, 3 fail-safe outputs	VQFN-48
TLE9278-3QX	Multi-CAN Power SBC	5 Mbit/s	30	55	750 mA @ 5 V		400 mA @ 5 V/3.3 V/1.8 V/1.2 V	4x CAN FD		1 high-voltage	Yes (window watchdog)	1 fail-safe output	VQFN-48
TLE9278-3QX V33	Multi-CAN Power SBC	5 Mbit/s	30	55	750 mA @ 3.3 V		400 mA @ 5 V/3.3 V/1.8 V/1.2 V	4x CAN FD		1 high-voltage	Yes (window watchdog)	1 fail-safe output	VQFN-48

1) See packages on page 36

2) CAN FD up to 2 Mbit/s

3) CAN PN FD tolerant

4) Coming Q2/2017



BAHNHOF POTSDAMER PLATZ

DB



Infineon® Embedded Power ICs

System-on-Chip motor control

Infineon® Embedded Power ICs are specifically designed to enable mechatronic motor control solutions for a range of motor control applications, where a small package form factor and a minimum number of external components are essential. Such applications include window lift, sunroof, wiper, fuel pump, HVAC fans, engine cooling fan and water pumps, to name but a few.

Produced on Infineon’s first-in-industry automotive-qualified Smart Power technologies, the Infineon Embedded

Power System-on-Chip (SoC) solutions offer an unmatched level of integration of all functions required to sense, control and actuate a motor.

The Infineon® Embedded Power ICs integrate on single die the microcontroller, the non-volatile flash memory, the analog and mixed signal peripherals, the communication interfaces along with the driving stages needed for either relay, half-bridge or full-bridge DC and BLDC motor applications.

Selection tree – Infineon Embedded Power IC motor control

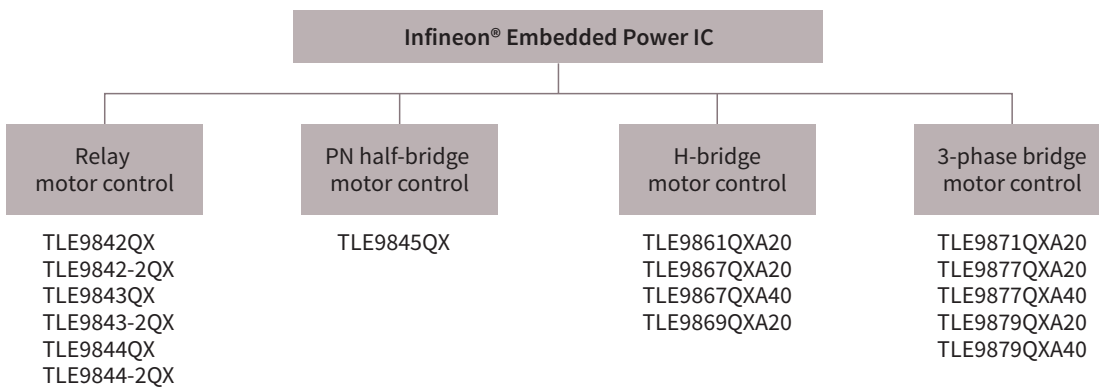

3rd generation: relay driver IC with integrated microcontroller

The TLE984x product family brings together the ARM® Cortex®-M0 core and the market proven peripherals of its predecessor TLE983x (XC800 based relay driver). It integrates on a single die all the necessary functions to sense, control and actuate a motor via a relay or via a PN MOSFET half-bridge.

Produced on Infineon's first-in-industry automotive-qualified 130 nm Smart Power technology, the Infineon Embedded Power system-on-chip solution offers an unmatched level of integration as well as system cost to performance optimization for the target application segments.

TLE984x family offers

- › Two protected low-side switches (min. 270 mA)
- › Up to two protected high-side switches (min. 150 mA)
- › Up to five high-voltage inputs with wake-up functionality
- › Integrated LIN transceiver compatible with LIN 2.2 and SAEJ2602
- › Two full duplex serial interface (UART) with LIN support
- › Two Synchronous Serial Channel (SSC), compatible with SPI
- › On-chip oscillator and PLL for clock generation
- › Measurement unit:
 - 8-bit ADC module with 7 multiplexed inputs for system supervision
 - 10-bit ADC module with 13 multiplexed inputs
 - On chip temperature and battery voltage measurement
- › Independent programmable window watchdog
- › 5 V/1.5 V internal supplies
- › External supply (V_{DDEXT}): 5 V \pm 2% @ 20 mA
- › Power saving modes
 - MCU slow-down mode
 - Sleep mode
 - Stop mode
 - Cyclic wake-up from sleep mode or stop mode

The TLE984x family concept offers scalability in terms of flash memory sizes ranging from 36 kB to 64 kB with pin-compatible devices.

The TLE984x family is the successor of the TLE983x product family and specifically designed to fit to a wide range of LIN-slave motor control applications such as window lifts, wipers, sun roofs, fans and blowers to name a few.

The TLE984x product family is offered in a space saving VQFN-48 package.

Features of the microcontroller and its peripherals

- › 32-bit ARM® Cortex®-M0 Core, up to 25/40 MHz clock frequency
- › 36 KB to 64 KB flash memory for code and data
- › Boot ROM for startup firmware and flash routines
- › Up to 4 kByte RAM memory
- › Thumb® + Thumb-2® Instruction Set
- › Nine 16-bit timers
- › Capture/compare unit for PWM signal generation (CCU6) with 2 x 16-bit timers

General characteristics

- › Operating supply voltage $V_S = 5.5$ to 28 V, maximum rating 40 V
- › Extended operating range $V_S = 3.0$ to 28 V, MCU/flash fully functional
- › Wide operating temperature range:
 T_j : -40°C up to 150°C

Applications

- › Window lift
- › Sun roof
- › Wiper
- › Fan/blower control
- › Relay motor via relay
- › Switch panel interface

Infineon® Embedded Power ICs

TLE984x product overview

Product name	Core	Flash [kB]	RAM [kB]	EEPROM in flash included [kB]	Freq [MHz]	High-side switch	High-voltage monitor input	GPIO	Analog inputs	PN MOS driver	Interface	Package ¹⁾
Relay driver IC with integrated microcontroller												
TLE9842QX	Cortex®-M0	36	2	4	25	1	4	10	6	No	PWM + LIN	VQFN-48
TLE9842-2QX	Cortex®-M0	40	2	4	40	2	5	10	6	No	PWM + LIN	VQFN-48
TLE9843QX	Cortex®-M0	48	4	4	25	1	4	10	6	No	PWM + LIN	VQFN-48
TLE9843-2QX	Cortex®-M0	52	4	4	40	2	5	10	6	No	PWM + LIN	VQFN-48
TLE9844QX	Cortex®-M0	64	4	4	25	1	4	10	6	No	PWM + LIN	VQFN-48
TLE9844-2QX	Cortex®-M0	64	4	4	40	2	5	10	6	No	PWM + LIN	VQFN-48
Half-bridge driver IC with integrated microcontroller												
TLE9845QX	Cortex®-M0	48	4	4	40	2	5	10	6	Yes	PWM + LIN	VQFN-48

1) See packages on page 36

Embedded Power ICs TLE984xQX: smart window lift application diagram

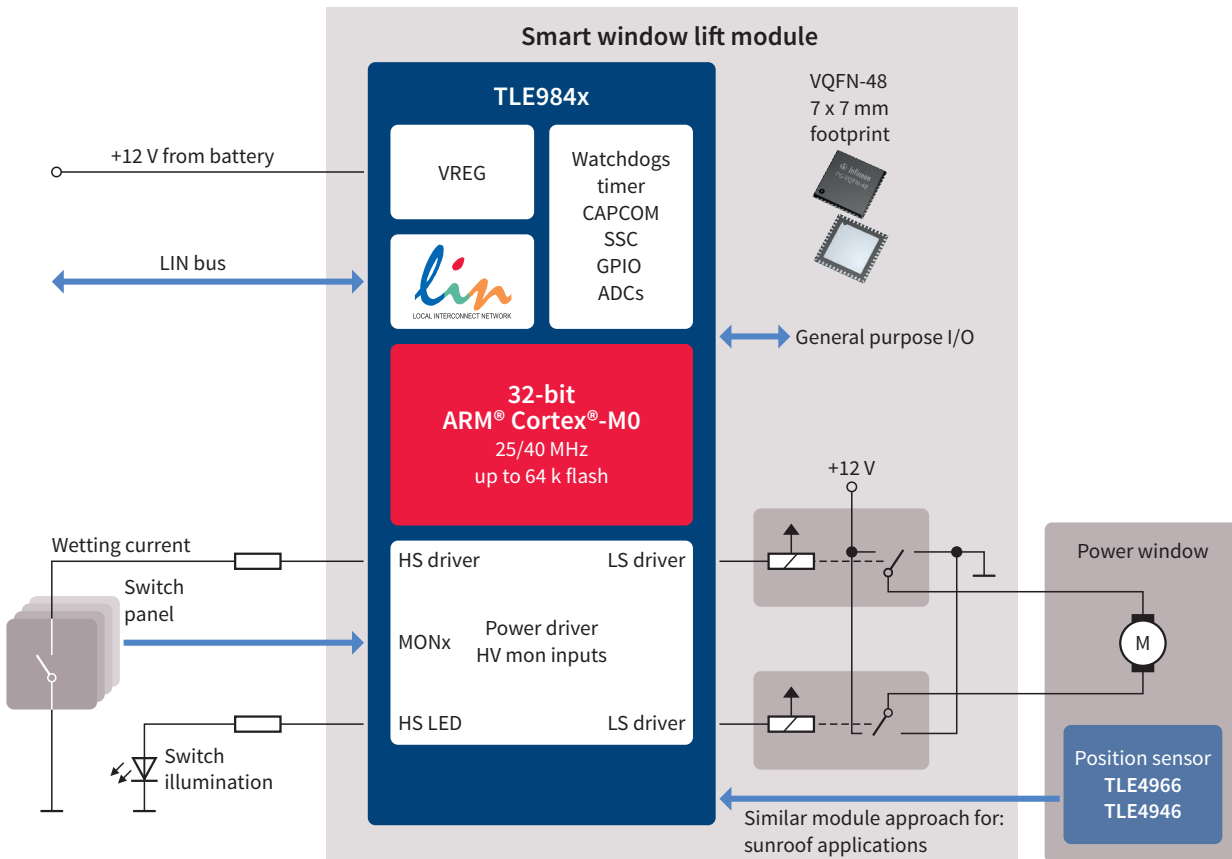

3rd generation: 2-phase bridge driver IC with integrated ARM® Cortex®-M3 core

Infineon has combined its wealth of experience in motor control drivers for automotive applications with an industry-standard core. The unique result, our 3rd generation Embedded Power IC based on ARM® Cortex®-M cores, addresses a wide range of smart 2-phase DC motor control applications like, sunroof, power window lift, electrical pumps, electrical fans.

Produced on Infineon's first-in-industry automotive-qualified 130 nm Smart Power technology, the Infineon Embedded

Power system-on-chip solutions offer an unmatched level of integration and system cost to performance to optimization for the target application segments.

The TLE986x family offers scalability in terms of flash memory sizes and MCU system clock frequency supporting a wide range of motor control algorithms. It uses the same MCU and peripherals as the TLE987x family, 3-phase driver, enabling design synergies between DC and BLDC motor control applications

TLE986x family offers

- › Four current programmable drivers with charge pump for N-Channel MOSFET
- › Integrated LIN transceiver compatible with LIN 2.2 and SAE J2602
- › Two full duplex serial interface (UART) with LIN support
- › Two Synchronous Serial Channel (SSC)
- › On-chip OSC and PLL for clock generation
- › One high-voltage monitoring input with wake-up functionality
- › High-speed operational amplifier for motor current sensing via shunt
- › Measurement unit
 - 8-bit ADC module with 10 multiplexed inputs
 - 10-bit ADC module with 8 multiplexed inputs, 5 external analog inputs
 - On chip temperature and battery voltage measurement unit
- › Independent programmable window watchdog
- › 5 V/1.5 V Internal supplies
- › External supply (V_{DDEXT}): 5 V \pm 2% @ 20 mA
- › Power saving modes
 - MCU slow-down mode
 - Sleep mode
 - Stop mode
 - Cyclic wake-up sleep mode

Features of the microcontroller

- › 32-bit ARM® Cortex®-M3 Core, up to 40 MHz clock frequency
- › 36 KB to 128 KB flash memory
- › Up to 6 KB RAM memory
- › Harvard architecture
- › Thumb®-2 Instruction Set and hardware divide and multiplication unit
- › Four 16-bit timers
- › Capture/compare unit for PWM signal generation (CCU6) with 2x 16-bits timers

General characteristics

- › Operating supply voltage $V_S = 5.5$ to 28 V, maximum rating 40 V
- › Extended operating range $V_S = 3.0$ to 28 V, MCU/flash fully functional
- › ESD performance
 - up to 2 kV / handling on all pins
 - 4 kV @ HV inputs
 - 6 kV @ LIN pin
- › Overvoltage device clamp (load dump ruggedness) up to 40 V
- › Wide operating temperature range:
 T_j : -40°C up to 150°C

Infineon® Embedded Power ICs

Block diagram

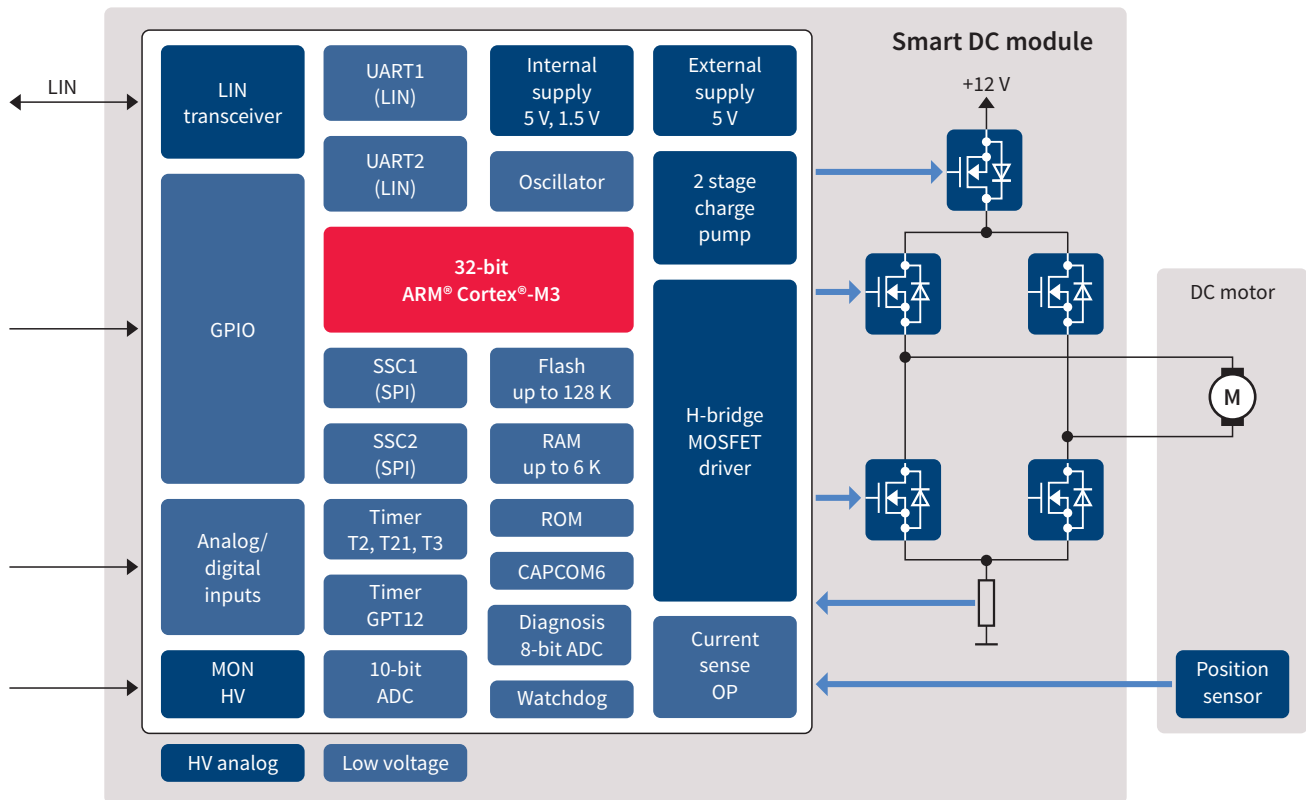

TLE986x 32-bit µC with 2-phase MOSFET Gate Driver for DC motors

Product name	Frequency [MHz]	Interface	RAM [KB]	Flash [KB]	EEPROM emulation [KB]	OP-AMP	Low-side MOSFET drivers	High-side MOSFET drivers	Package ¹⁾
TLE9861QXA20	24	PWM	3	36	4	y	2	2	VQFN-48
TLE9867QXA20	24	PWM + LIN	6	64	4	y	2	2	VQFN-48
TLE9867QXA40	40	PWM + LIN	6	64	4	y	2	2	VQFN-48
TLE9869QXA20	24	PWM + LIN	6	128	4	y	2	2	VQFN-48

1) See packages on page 36

3rd generation: 3-phase bridge driver IC with integrated ARM® Cortex®-M3 core

Infineon has combined its wealth of experience in motor control drivers for automotive applications with all the benefits of an industry-standard core. The unique result, our 3rd generation Embedded Power IC based on ARM® Cortex®-M cores, addresses a wide range of smart 3-phase brushless DC motor control applications like, fuel pumps, HVAC fans, engine cooling fans, electrical water pumps. Produced on Infineon's first-in-industry automotive-qualified 130 nm Smart Power technology, the Infineon Embedded Power system-on-chip solutions

offer an unmatched level integration and system cost to performance to optimization for the target application segments.

The TLE987x family offers scalability in terms of flash memory sizes and MCU system clock frequency supporting a wide range of motor control algorithms, either sensor-based or sensor-less. It uses the same MCU and peripherals as the TLE986x family, 2-phase driver, enabling design synergies between DC and BLDC motor control applications.

TLE987x family offers

- › Six current programmable drivers with charge pump for N-Channel MOSFET
- › Integrated LIN transceiver compatible with LIN 2.2 and SAE J2602
- › Two full duplex serial interface (UART) with LIN support
- › Two Synchronous Serial Channel (SSC)
- › On-chip OSC and PLL for clock generation
- › One high-voltage monitoring input with wake-up functionality
- › High-speed operational amplifier for motor current sensing via shunt
- › Measurement unit
 - 8-bit ADC module with 10 multiplexed inputs
 - 10-bit ADC module with 8 multiplexed inputs, 5 external analog inputs
 - On chip temperature and battery voltage measurement unit
- › Independent programmable window watchdog
- › 5 V/1.5 V internal supplies
- › External supply (V_{DDEXT}): 5 V \pm 2% @ 20 mA
- › Power saving modes
 - MCU slow-down mode
 - Sleep mode
 - Stop mode
 - Cyclic wake-up sleep mode

Features of the microcontroller

- › 32-bit ARM® Cortex®-M3 Core, up to 40 MHz clock frequency
- › 36 KB to 128 KB flash memory
- › Up to 6 KB RAM memory
- › Harvard architecture
- › Thumb®-2 Instruction Set and hardware divide and multiplication unit
- › Four 16-bit timers
- › Capture/compare unit for PWM signal generation (CCU6) with 2x 16-bits timers

General characteristics

- › Operating supply voltage $V_S = 5.5$ to 28 V, maximum rating 40 V
- › Extended operating range $V_S = 3.0$ to 28 V, MCU/flash fully functional
- › ESD performance
 - up to 2 kV / handling on all pins
 - 4 kV @ HV inputs
 - 6 kV @ LIN pin
- › Overvoltage device clamp (load dump ruggedness) up to 40 V
- › Wide operating temperature range:
 T_j : -40°C up to 150°C

Infineon® Embedded Power ICs

Block diagram

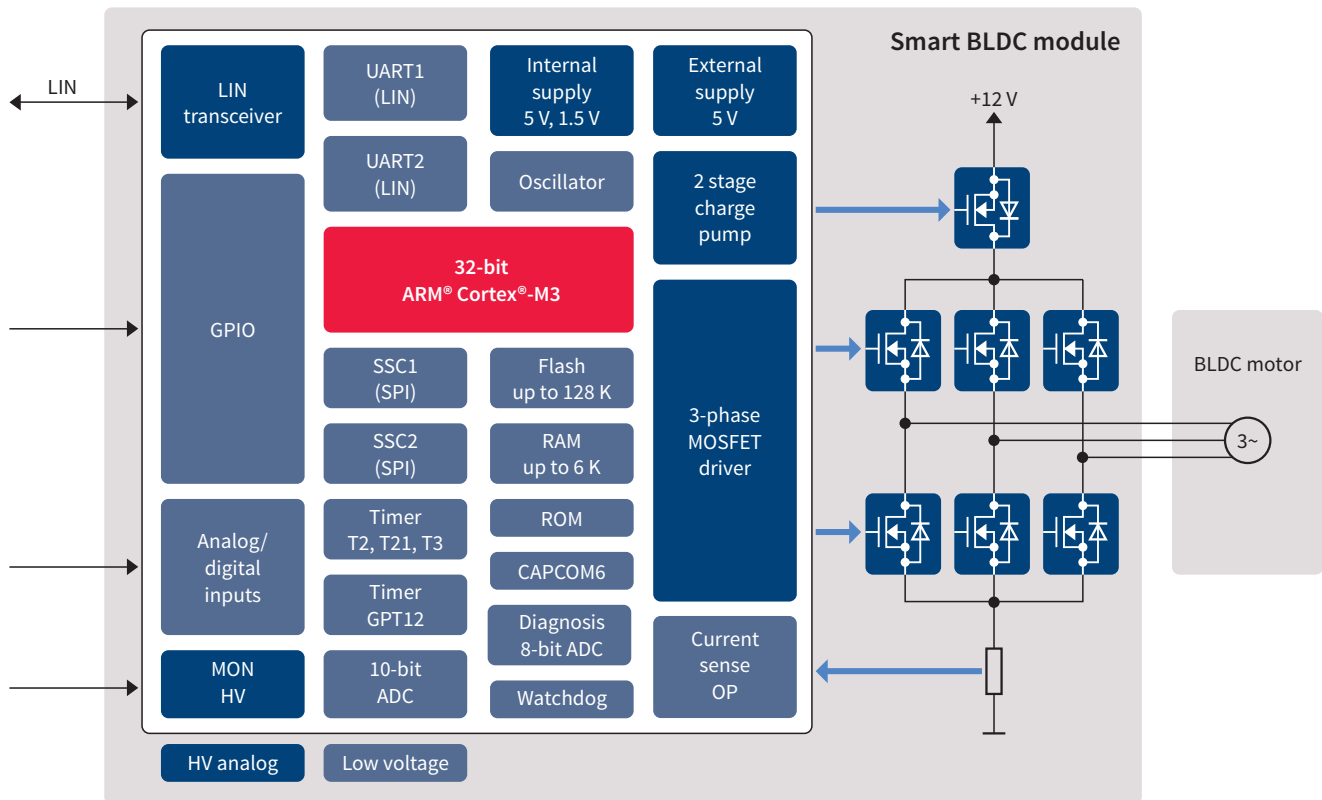

TLE987x 32-bit µC with 3-phase MOSFET Gate Driver for BLDC motors

Product name	Frequency [MHz]	Interface	RAM [KB]	Flash [KB]	EEPROM emulation [KB]	OP-AMP	Low-side MOSFET drivers	High-side MOSFET drivers	Package ¹⁾
TLE9871QXA20	24	PWM	3	36	4	y	3	3	VQFN-48
TLE9877QXA20	24	PWM + LIN	6	64	4	y	3	3	VQFN-48
TLE9877QXA40	40	PWM + LIN	6	64	4	y	3	3	VQFN-48
TLE9879QXA20	24	PWM + LIN	6	128	4	y	3	3	VQFN-48
TLE9879QXA40	40	PWM + LIN	6	128	4	y	3	3	VQFN-48

1) See packages on page 36

Powerful next-generation AURIX™ TC3xx microcontroller family

With its up to hexa-core high performance architecture and advanced features for connectivity, security and functional safety, the AURIX™ 2nd Generation microcontroller TC3xx family is ideally suited for a wide field of automotive and industrial applications. In addition to conventional powertrain applications e.g. engine management and transmission control, AURIX™ 2nd Generation well serves performance hungry applications like domain control. Designed to answer uprising demands in hybrid and electric vehicles, AURIX™ 2nd Generation offers a variety of high speed interface ideal for hybrid domain control, its DS-ADC module aided with software can achieve integrated resolver-to-digital functionality, which is an essential part of electric motor positioning. Its embedded standby controller can work under ultra-low power consumption hence enabling battery management under holiday parking. Most importantly, the newly introduced peak current control feature ensures the MCU's competence in high voltage to 12 volt DC-DC converters.

The AURIX™ TC3xx microcontrollers are also well-suited to safety-critical applications ranging from airbag, braking and power steering to sensor based systems using radar or camera technologies. The combination of performance and a powerful safety architecture makes the family ideal fit for domain control and data fusion applications supporting the next levels of autonomous driving. Thanks to the Infineon deep system know-how of the targeted applications, AURIX™ TC3xx comes with a high integration of external functionalities and components allowing further bill of material cost optimization, compact board designs and fail operational systems for autonomous driving.

As a host controller in gateway and telematics applications, AURIX™ TC3xx microcontrollers support the latest communications interfaces and feature a Gigabit Ethernet interface, up to 12 ISO11898-1 compliant CAN-FD channels and, up to 24 LIN channels. An additional eMMC interface for external Flash interfacing enables local data storage supporting software-over-the-air update concepts.

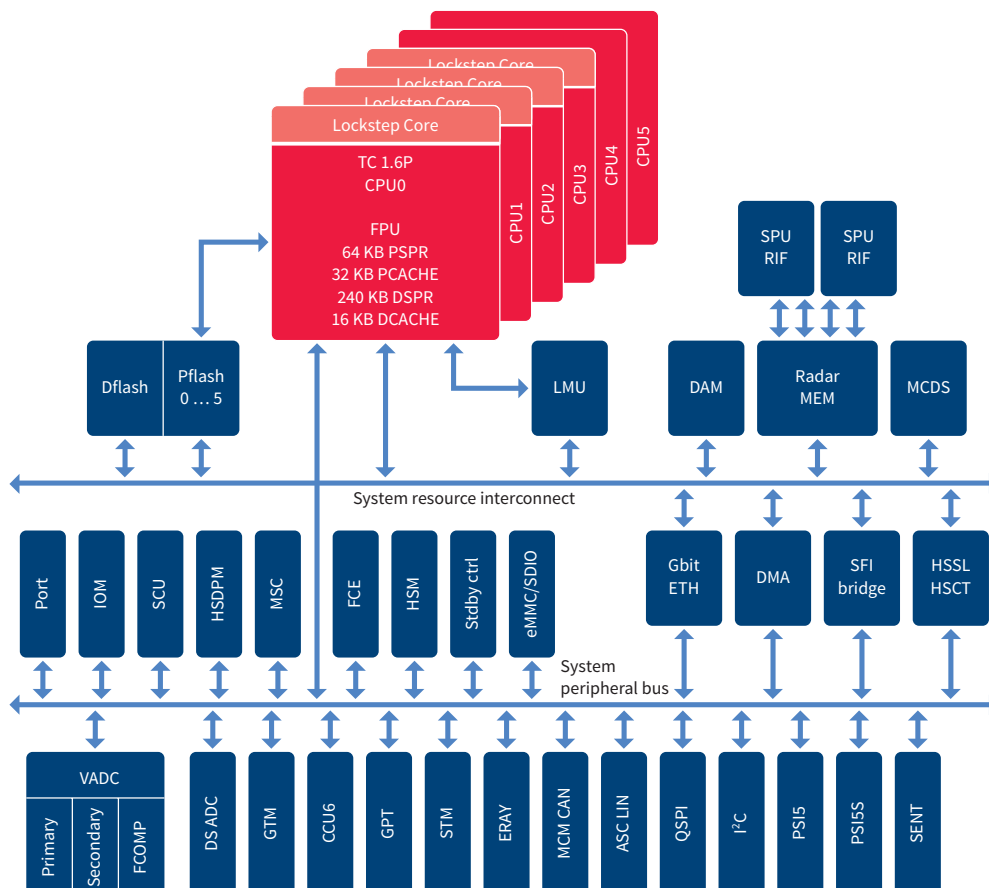

AURIX™ 1st generation family package scalability

	TQFP-80	TQFP-100	LQFP-144 TQFP-144	LQFP-176	LFBGA-292	BGA-416	LFBGA-516
9x series up to 8 MB max. SRAM 2.75 MB triple-core					TC297	TC298	TC299
7x series up to 4 MB max. SRAM 472 KB triple-core				TC275	TC277		
6x series up to 2.5 MB max. SRAM 752 KB dual-core			TC264	TC265	TC267		
3x series up to 2 MB max. SRAM 708 KB Lockstep-core		TC233	TC234		TC237		
2x series up to 1 MB max. SRAM 96 KB Lockstep-core	TC222	TC223	TC224				
1x series up to 512 KB max. SRAM 56 KB Lockstep-core	TC212	TC213	TC214				

 Upgrade/downgrade with pin-compatible packages

- › Advanced package technologies deliver the best price/performance ratio
- › Customers can choose between different devices in the same pin-compatible package

TriCore™ upgrade paths

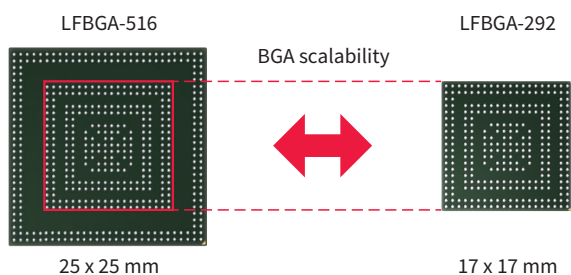

- › LFBGA-292 and LFBGA-516 are ball compatible so that customers can build one PCB for both packages

AURIX™ 1st generation family communication innovation

AURIX™ MultiCAN

- › Up to 6 CAN nodes with FD support available
- › CAN standard V2.0 B active
- › Full AURIX™ support for ISO11898-1:2015
- › Specific AURIX™ variants support ISO11898-1 DIS 2015
- › Resonator ready with asynchronous operation and choice of clock source
- › Frequency scaling without baud rate change
- › Energy saving: pretended networking and partial networking (ISO11898-6 transceiver support) support (also in CAN FD mode)
- › Safety support: total amount of bus errors countable
- › Message objects can be freely assigned among the nodes
- › Configurable FIFO length, automatic gateway mode support
- › Acceptance mask filtering for each message object



Ethernet

Highlights

- › MAC integrated in μ C
- › IEEE 802.3-2002 for Ethernet with support of IP, TCP/IP, UDP ...
- › Real-time stamping support (IEEE 1588-2008) for clock synchronization
- › Standard MII and RMI interfaces to PHY
- › Fast Ethernet w/ 100 Mbit
- › AUTOSAR V4 features supported
- › Automatic CRC checksum and padding support
- › AVB support

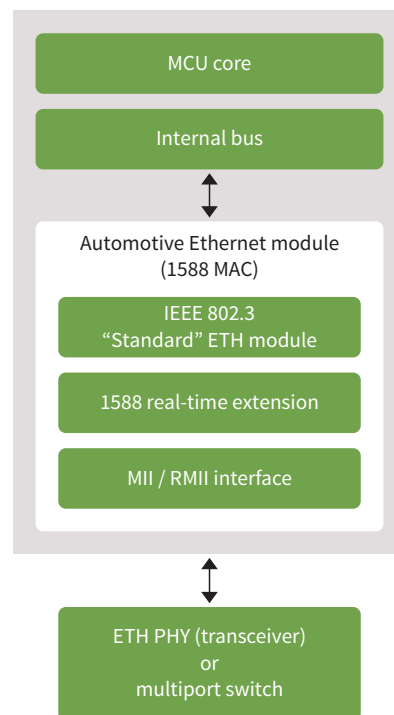

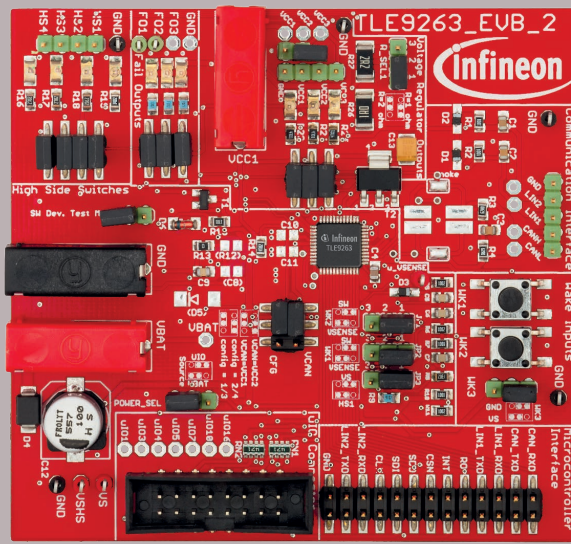

Support tools automotive transceivers

The universal CAN demoboard

The HS CAN transceiver demoboard can be used for all standard HS CAN transceivers, which fulfill the OEM required standard pinout for 8-pin and 14-pin DSO packages. Additionally it is also suited for CAN transceivers with Partial Networking capability as well as CAN FD transceivers.

Further information

User manuals with software and hardware recommendation, FAQs, data sheets along with development tools can be found at www.infineon.com/automotive-transceivers

Support tools System Basis Chips (SBCs)

Midrange SBC board

This demo board enables device evaluation of the Mid-Range SBC product family and accelerates the design-in phase. The evaluation board can be connected to the “UIO STICK” (Power Easy Kit Lite) and controlled via USB using a powerful and intuitive Graphical User Interface (GUI) installed on your computer.

Multi-CAN SBC board

This demo board enables device evaluation of the Multi-CAN Power SBC product family and accelerates the design-in phase. The evaluation board can be connected to the “UIO STICK” (Power Easy Kit Lite) and controlled via USB using a powerful and intuitive Graphical User Interface (GUI) installed on your computer.

Further information

User manuals with software and hardware recommendation, FAQs, data sheets along with development tools can be found at www.infineon.com/sbc



Support tools Embedded Power

TLE984X evaluation board

The TLE984x evaluation board offers complete evaluation of all functions and peripherals of the TLE984x product family.

TLE9845 evaluation board

The TLE9845 evaluation board offers complete evaluation of all functions and peripherals of the TLE9845QX variant of the TLE984x product family.

H-bridge driver IC with integrated microcontroller evaluation kit TLE986x

The TLE986X EVALB_JLINK offers complete evaluation of all functions and peripherals of the TLE986x product family and allows direct connection to a DC motor via MOSFETS in H-bridge configuration, it includes: H-bridge for DC motor drive, UART and LIN for communication, direct access to all device I/Os and a J-link debugger.

B6-bridge driver IC with integrated microcontroller evaluation kit TLE987x

The TLE987X EVALB_JLINK offers complete evaluation of all functions and peripherals of the TLE987x product family and allows direct connection to a BLDC motor via MOSFETS in B6- bridge configuration, it includes: B6-bridge for BLDC motor drive, UART and LIN for communication, direct access to all device I/Os and a J-link debugger.

Infineon® Embedded Power ICs are supported by a complete development tool chain provided by Infineon and third party vendors. The tool chain includes compilers, debuggers, evaluation boards, LIN low-level drivers and configuration tools as well as variety of example software code.

Further information

User manuals with software and hardware recommendation, FAQs, data sheets along with development tools can be found at

www.infineon.com/embeddedpower

Support tools microcontrollers

ACT- AURIX™ configuration tool

ACT is a powerful tool that helps engineers to jump-start programming of Infineon microcontrollers.

Key feature

- > Altium TASKING VX TriCore™ lite version including build-in
 - AURIX™ pin mapping incl. interactive package view
 - AURIX™ iLLD (Low-Level Driver)
 - AURIX™ OSEK

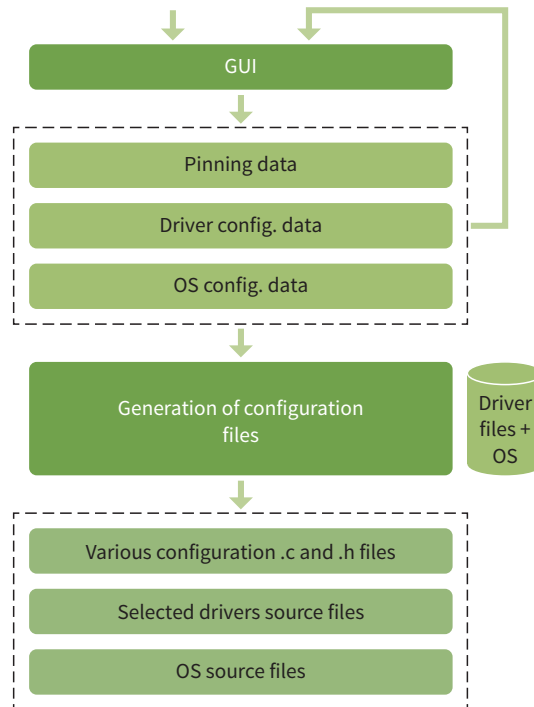

Expert kits

Infineon TriCore™ family starter kits are powerful evaluation systems that enable evaluation and development well before the target hardware is available. They offer a solid platform for both hardware and software engineers to evaluate and prototype designs that are closely aligned with their final applications.

Our kits Include







- > Full-featured evaluation board
- > USB cable
- > Easy connectivity to all peripheral modules
- > Extension board
- > Development tools for evaluation such as compilers, debuggers and DAVE™
- > Technical documentation – user manuals, architecture manuals, application notes, data sheets, board documentation

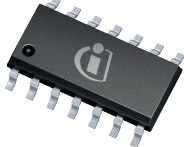
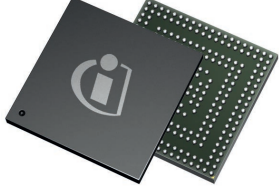
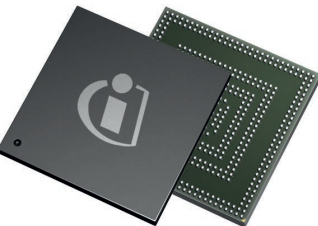
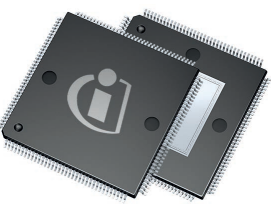
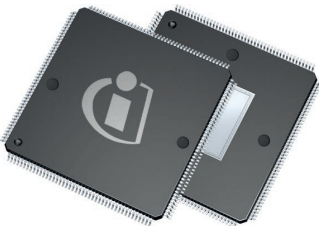
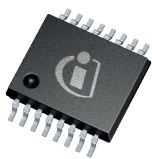

Further information on TriCore™ starter kits:

<http://ehitex.com/starter-kits/for-tricore>

Package information

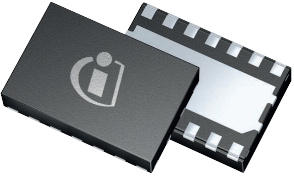
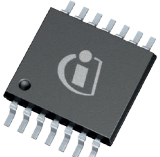
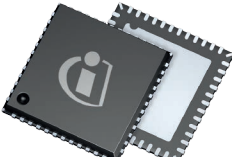
BGA-416	DSO-8	DSO-14	LFBGA-292
			
LFBGA-516	LQFP-144	LQFP-176	SSOP-16
			
TQFP-80	TQFP-100	TQFP-144	TSOP-8
			
TSOP-14	TSSOP-14	VQFN-48	
			

Where to buy

Infiniteon distribution partners and sales offices:

www.infineon.com/WhereToBuy

Service hotline

Infiniteon offers its toll-free 0800/4001 service hotline as one central number, available 24/7 in English, Mandarin and German.

- > Germany 0800 951 951 951 (German/English)
- > China, mainland 4001 200 951 (Mandarin/English)
- > India 000 800 4402 951 (English)
- > USA 1-866 951 9519 (English/German)
- > Other countries 00* 800 951 951 951 (English/German)
- > Direct access +49 89 234-0 (interconnection fee, German/English)

* Please note: Some countries may require you to dial a code other than "00" to access this international number.
Please visit www.infineon.com/service for your country!



Mobile product catalog

Mobile app for iOS and Android.

www.infineon.com

Published by
Infineon Technologies AG
81726 Munich, Germany

© 2016 Infineon Technologies AG.
All rights reserved.

Order number: B124-I0064-V2-7600-EU-EC
Date: 11 / 2016

Please note!

THIS DOCUMENT IS FOR INFORMATION PURPOSES ONLY AND ANY INFORMATION GIVEN HEREIN SHALL IN NO EVENT BE REGARDED AS A WARRANTY, GUARANTEE OR DESCRIPTION OF ANY FUNCTIONALITY, CONDITIONS AND/OR QUALITY OF OUR PRODUCTS OR ANY SUITABILITY FOR A PARTICULAR PURPOSE. WITH REGARD TO THE TECHNICAL SPECIFICATIONS OF OUR PRODUCTS, WE KINDLY ASK YOU TO REFER TO THE RELEVANT PRODUCT DATA SHEETS PROVIDED BY US. OUR CUSTOMERS AND THEIR TECHNICAL DEPARTMENTS ARE REQUIRED TO EVALUATE THE SUITABILITY OF OUR PRODUCTS FOR THE INTENDED APPLICATION.

WE RESERVE THE RIGHT TO CHANGE THIS DOCUMENT AND/OR THE INFORMATION GIVEN HEREIN AT ANY TIME.

Additional information

For further information on technologies, our products, the application of our products, delivery terms and conditions and/or prices, please contact your nearest Infineon Technologies office (www.infineon.com).

Warnings

Due to technical requirements, our products may contain dangerous substances. For information on the types in question, please contact your nearest Infineon Technologies office.

Except as otherwise explicitly approved by us in a written document signed by authorized representatives of Infineon Technologies, our products may not be used in any life-endangering applications, including but not limited to medical, nuclear, military, life-critical or any other applications where a failure of the product or any consequences of the use thereof can result in personal injury.